

Plan Review Checklist – Detached Garages

Home Owner/Builders: The following information is required when submitting an application for a residential building permit and before a building permit is issued. The plan review will not begin until all required information is provided.

Required Information:

- 2 sets of **Site Plans** with the following information
 - Show size and location of proposed garage
 - Show size and location of existing buildings on property
 - Show lot dimensions and shape
 - Show distance between buildings and property lines
 - Show North direction arrow
- 2 sets of **Garage Layout Drawings** with the following information
 - Interior wall location
 - Window sizes and locations
 - Door sizes, location and swing direction
 - Heating unit/system location (if applicable)
- 2 copies of the **Detached Garage Checklist** properly filled out
- 2 copies of the **Building Permit Application** properly filled out

Required On-Site Inspections: (inspection requirements may change depending on the project type and size)

- Plan Review (Prior to the commencement of any construction)
- Framing (Prior to insulating and applying vapour barrier the exterior walls)
- Final (Prior to moving in or occupying the building)

Detached Garge Checklist

Site Plan

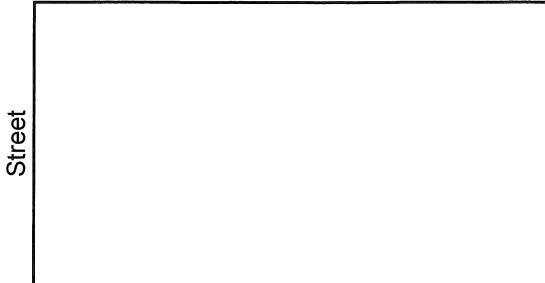

On Site Plan:

- Show size and location of proposed garage
- Show distance to side property line
- Show distance to rear property line
- Show distance to house
- Show lot dimensions and shape of lot
- Show all existing buildings
- Show direction of North
- Show all windows and doors on existing structures

Wall System

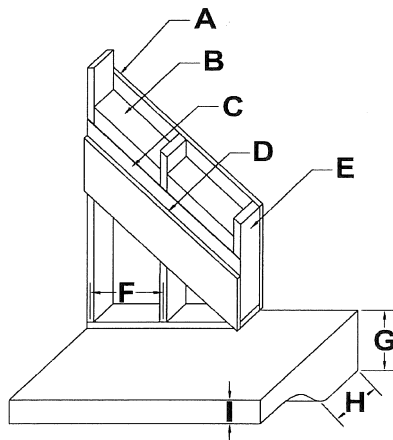

Roof System

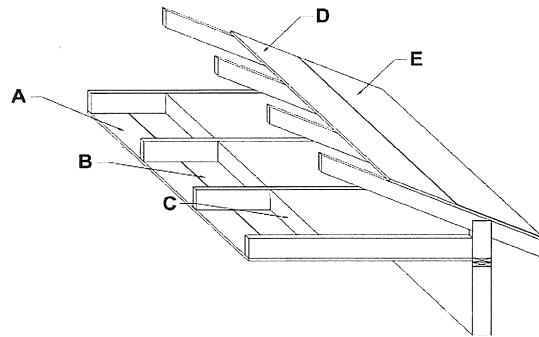

Wall System	Roof System
A - Outside Sheathing:	A - Interior Finish:
B - Insulation Value:	B - Type of Vapour Barrier:
C - Type of Vapour Barrier:	C - Insulation Value:
D - Interior Finish:	D - Exterior Sheathing:
E - Stud Size	E - Type of Roofing:
F - Stud Spacing	Roof Overhang
G - Size of Thickend Edge:	Garage Door
H - Width of Thickend Edge:	Door Span _____
I - Thickness of Pad:	Lintel Size _____
Wall Height _____	Ply _____

I hereby acknowledge that I have read this application and state that the above is correct and agree to comply with all Municipal By-Laws and/or Provincial Laws regulating building. It being expressly understood that the issuing of a permit does not relieve the applicant from complying with all By-Laws, though not called for in the specifications, or shown on plans and/or application submitted.

Applicant (Print Please) _____ Date _____

Applicant Signature _____ Date _____

Application Received By _____

